



## ▶ AMTRAK BOREALIS SERVICE LAUNCHED

Amtrak’s Borealis service, sponsored by the states of Minnesota, Wisconsin and Illinois, launched May 21. The new state-sponsored trains originate from St. Paul at midday and from Chicago in late morning via Milwaukee, offering coach and business class accommodations. In addition to a café car featuring regional items, customers enjoy wide reclining seats with ample legroom, no middle seats, free Wi-Fi and views of the Mississippi River between St. Paul and La Crosse, Wis.

Borealis trains between St. Paul and Chicago reached the 100,000-customer mark by late October, demonstrating high demand for the service. To celebrate, customers were given complimentary refreshments and commemorative certificates entitling every passenger to 500 bonus Amtrak Guest Rewards points. As a fun addition, each passenger received a “100 Grand” candy bar, courtesy of Amtrak.

## ▶ NUMBER OF TRANSIT PROVIDERS IN ILLINOIS

**59**



**44** IN RURAL AREAS  
**15** IN URBAN AREAS  
*(INCLUDES SERVICE BOARDS)*

101 COUNTIES IN ILLINOIS PROVIDE PUBLIC TRANSIT.



**IDOT**

## ▶ PEORIA’S MASS TRANSIT DISTRICT GETS NEW FACILITY



Peoria’s Mass Transit District, CityLink, is nearing completion of a new three-story building for maintenance, operations and administration that broke ground in May 2022. The improvements will modernize overall operations and boost safety.

Project funding includes Rebuild Illinois grants, local match funding from IDOT and grants from the Federal Transit Administration as part of the Buses and Bus Facilities Infrastructure Invest program.

Improvements include 10 pull-through maintenance bays including one with an overhead crane and eight with lifts for improved safety, state-of-the-art maintenance operations for increased reliability, operators’ day room with direct interior access to the bus storage garage via a new skywalk, administration center with boardroom and photovoltaic panels to generate solar energy.



# SAFETY

**Keeping people safe as they** move through their daily lives is a chief priority of our work. Through raising awareness, assisting motorists and facilitating other critical programs, we are reducing risks and cultivating a transportation system that is centered on the people who rely upon it.



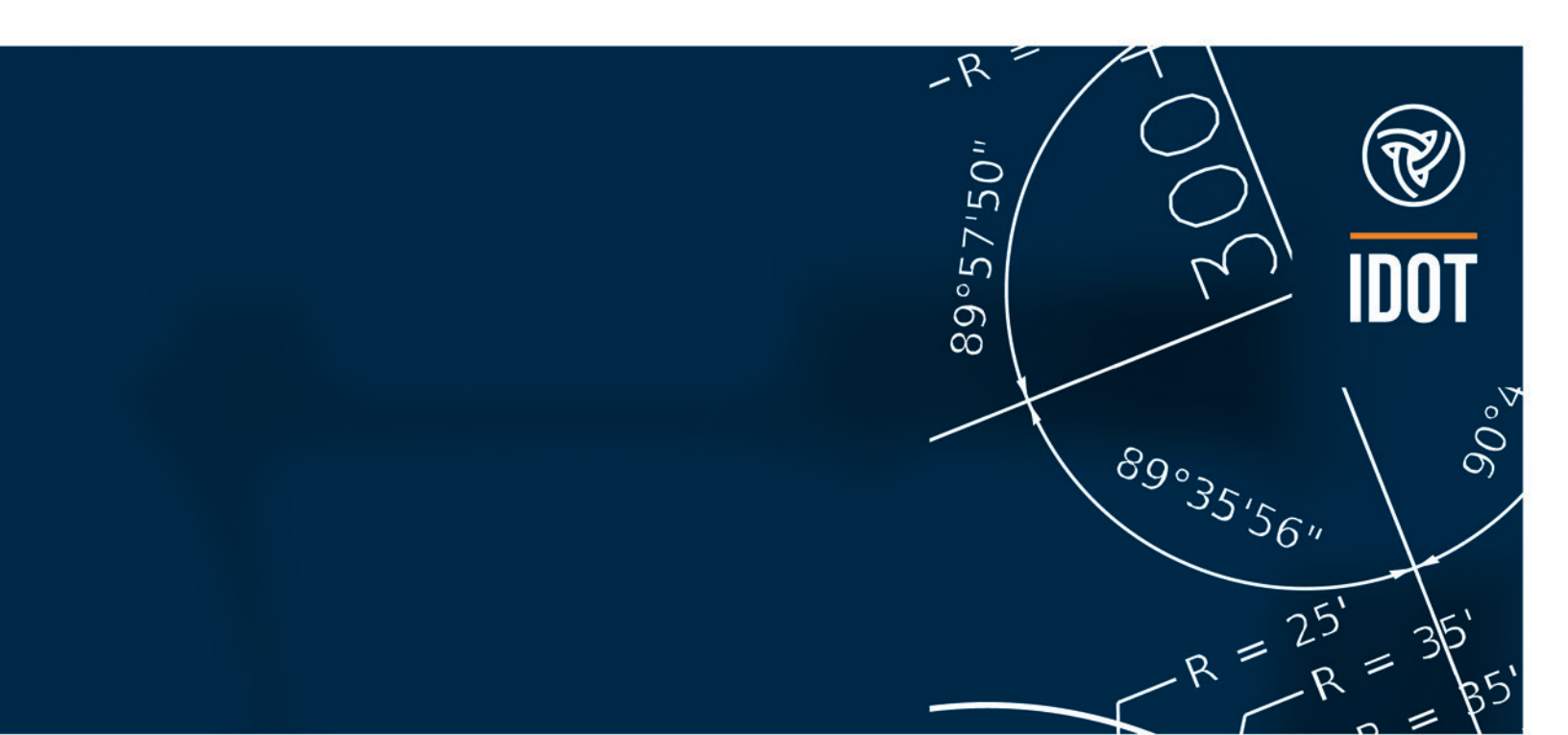



## ▶ NEW SPEED PHOTO ENFORCEMENT VANS COMING TO WORK ZONES

On May 2, one of IDOT's five new photo enforcement vans was at the Hanley Building to give employees an up-close look, with IDOT, Illinois State Police and vendor staff on hand to share information about the vans and how they will be used throughout Illinois work zones. The vehicles are the result of a new contract with Modaxo, which allows for as-needed equipment updates and a "train the trainer" program that will put operations firmly in the hands of IDOT and ISP.

Bearing clear markings designating them as speed photo enforcement vehicles, the vans feature updated technology and a large sign that displays the speed of approaching vehicles.

Highway Safety Programs Unit Chief Juan Pava said the improved technological features are a boon to the program.

"We have new cameras with much higher resolution, as well as new safety features within the units to keep the troopers who are deploying them safe," Pava said. "Speeding is one of the main causes of crashes in work zones. The vans give drivers ample warning that they may be going over the speed limit and the incentive to slow down before a speeding event is captured."

The goal is to save lives.

"This is not a revenue generating program. The primary benefit is speed reduction and behavior change," said Work Zone Safety Engineer Nathan Peck. "That's why we use a big white van. We want it to be visible. It's all about deterrence, presence and visibility."

ISP Captain Bill Langheim said that he's seen the program work firsthand.

"When drivers see these vehicles, it slows down traffic," Langheim said. "These are effective tools."

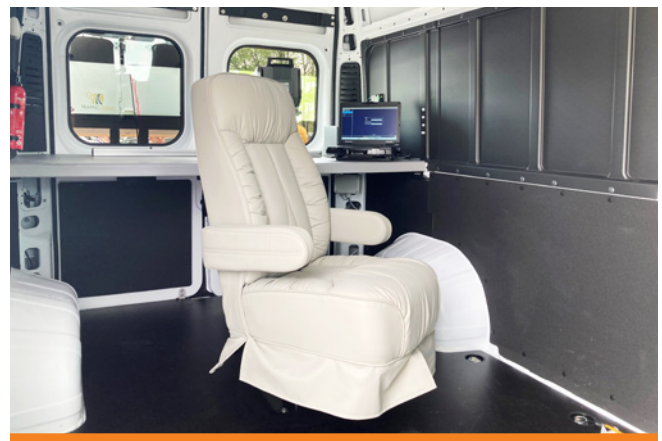

## ▶ NIL RULES ENABLE COLLEGE ATHLETES TO GO TO BAT FOR SAFETY

IDOT launched a new “It’s Not a Game” campaign to promote traffic safety awareness, targeting audiences aged 18-34. The initiative leverages the influence of college athletes to spread critical safety messages, including 35 student-athletes from state universities, like the University of Illinois and Northern Illinois University, who use their social media influence to address impaired driving and pedestrian safety.

With new NIL rules allowing athletes to use their name, image, and likeness for marketing, these athletes can connect directly with their peers on social media. Studies show they achieve engagement rates significantly higher than average on platforms like Instagram and TikTok. For instance, University of Illinois Urbana-Champaign athletes Luke Goode and Kayla Burbage created a St. Patrick’s Day safety video that gained considerable traction online. Northwestern quarterback Jack Lausch expressed pride in participating, emphasizing the campaign’s importance. Tori Thomas, a track athlete at the University of Illinois, noted that the initiative helps promote safety outside of athletics.

Funded by federal traffic safety grants, “It’s Not a Game” not only promotes safety but also redefines how government agencies communicate with youth on critical issues.



## ▶ IDOT'S CYCLE RIDER SAFETY TRAINING PROGRAM CLASSES RETURNING STATEWIDE

In partnership with Southern Illinois University, IDOT is once again offering its popular Cycle Rider Safety Training Program to any Illinois resident 16 and older with a valid driver's license. These classes also come with extra credit: Successful graduates can waive the written and riding portions of the Illinois motorcycle license exam that's administered by the Illinois Secretary of State's office.

After a break in having classes offered in all parts of the state due to an unexpected change in vendors teaching the courses, the program is starting to get back to full speed once again.

“The Cycle Rider Safety Training Program teaches riders the skills necessary to operate a motorcycle safely and confidently”, said Stephane B. Seck-Birhame, Bureau Chief of Safety Programs and Engineering. “Having a proper course for riding is the best option to be a professional rider. At IDOT, we are committed to safety for all road users. Reducing motorcycle crashes is an integral part of our

strategy in getting to zero fatalities in Illinois.”

Training motorcycles and helmets are provided in the basic courses. The classes are funded by motorcycle registration, with students paying a refundable \$20 for each course. However, according to Seck-Birhame, most riders choose to give back their course fee to pay it forward and help cover the costs for future riders.

The Cycle Rider Safety Training Program was established in 1976. SIU has been a pioneer in motorcycle education not only in Illinois, but in the nation, having established its own training program nearly 60 years ago. That makes SIU an ideal partner to administer the program statewide, Seck-Birhame said.

Because of the limited number of openings initially, registration backlogs are expected and patience is urged as the program gets ramped up across the rest of the state.



## ▶ IDOT/UIUC STUDY SHEDS LIGHT ON MESSAGE SIGN EFFECTIVENESS

Posted along interstates and highways, electronic dynamic message signs serve several purposes. They can inform drivers about everything from traffic and construction to weather conditions. They also may be used to promote safe driving habits and can be straightforward safety reminders, serious warnings or humorous pop culture references.

But what types of safety messages are most effective, and for which behaviors? That's the question the Illinois Center for Transportation at the University of Illinois Urbana-Champaign and IDOT sought to answer in a joint project.

Professor Yanfeng Ouyang led a six-month special project with Sean Martschinke, IDOT's bureau chief of Programs, Projects and Safety Outreach, to determine the effectiveness of these different types of messages on specific driver behaviors. The findings provided guidance on what types of messaging to use for targeted behaviors.

To investigate these questions, Ouyang's team developed an online simulation to gather data on drivers between the ages of 18 and 30 to simulate real-life driving conditions on a four-lane highway.

Players are positioned inside a vehicle and can control when to speed up, slow down, brake or change lanes, all while being exposed to various messaging on dynamic message signs. The participants also were given "distractions" they could engage with, such as taking phone calls or reading.

After completing the simulation, players reported their opinions of the dynamic message signs as well as their self-reported driving behaviors. The research team could also see if any driving behavior changed during the simulation when a dynamic message sign was present.

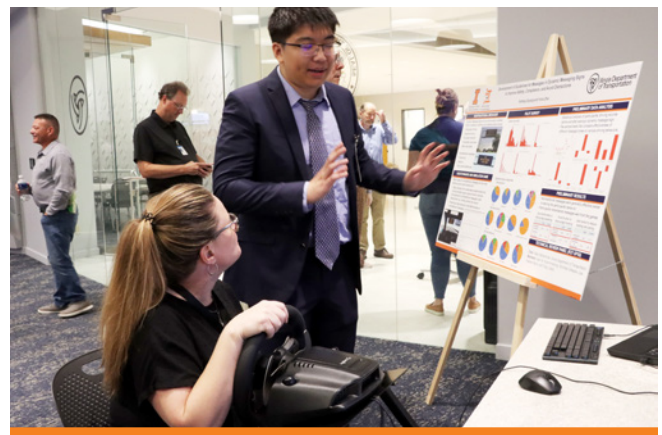



## ▶ WORK ZONE SAFETY FAIR A HIT AT ORANGE BARRELS GAME

IDOT again teamed up with the Peoria Chiefs at Dozer Park for year three at the Orange Barrels games — fun, construction-themed baseball mixed with some road safety education. The Chiefs first adopted the Orange Barrels branding in 2020 for a handful of games, inspired by construction that began on the nearby Murray Baker Bridge as a fun way to salute hard-working construction workers. IDOT saw this as the perfect opportunity to promote work zone safety and joined forces with the team. The collaboration even earned a 2023 TransComm award for best practice in public outreach.

For four games this season, 16,755 fans cheered on the home team while also learning about projects in the Peoria area and work zone safety. The Orange Barrels season ended with a pregame Safety Street Fair held just outside the gates of Dozer Park, where more than 75 fans participated in six interactive activity stations, driving home safety messages on important topics like speeding, distracted and impaired driving, and the importance of seatbelts. A final tent inside the gates on the concourse featured a video arcade with themed games from IDOT's statewide campaign, It's Not a Game, reinforcing more safety takeaways.

## ▶ PORTABLE SCALES ENFORCEMENT HELPS KEEP PUBLIC, ROADS SAFE

IDOT's Portable Scales Detail assists the Illinois State Police with commercial vehicle enforcement in parts of northern, central and western Illinois.

Made up of 12 two-person teams, the Portable Scales Detail is called when a trooper selects a truck to be pulled over and weighed. That's when the team sets up portable scales on the ground for the commercial vehicle to pull onto and weigh. In some cases, the state police requests teams with semi-portable scales, which can efficiently weigh a higher volume of trucks in a single location.

Because heavy trucks can do as much damage to the roads as thousands of passenger vehicles, weights must be properly managed to protect the roads.

The portable scales detail is making a difference. Portable scales team member Dave Vatland noted that compliance has increased in the past few years. Weight Enforcement Engineer Keith Donovan said from 2018 to 2022, the

portable scales detail has:

- ❑ Weighed an average 5,194 trucks on portable scales, with an average 767 citations a year.
- ❑ Weighed an average 19,433 trucks on semi-portable scales, with an average 262 citations a year.
- ❑ Resulted in an average \$2,115,603 in overweight fines a year.





# COMMUNITY IMPACT

**Our purpose is defined by** the people of Illinois, and we're committed to exceeding their expectations as a public agency. We strive to be a visible presence and offer meaningful opportunities to engage with our communities.







## ► RESEARCH SHOWCASE HIGHLIGHTS EFFORTS TO IMPROVE TRANSPORTATION

The first Research Showcase was held Oct. 9 in the Hanley Building auditorium. Attendees had the opportunity to talk with researchers and Technical Review Panel members to learn more about the collaboration between IDOT’s Bureau of Research and the Illinois Center for Transportation. The event brought together industry members and academic professionals to share details about their efforts to improve the transportation system in Illinois along with new research opportunities.

Three IDOT staff members helped kick off the event. Chief Operating Officer John Donovan gave opening remarks, Bureau Chief of Research John Senger provided an overview of the research program and Bureau Chief of Program, Project and Safety Outreach Sean Martschinke shared details of his ICT-IDOT research project on dynamic message signs and how IDOT implemented the results.

Exhibitors shared their research through poster presentations. One exhibit related to dynamic message signs had both a poster presentation and a hands-on demonstration. Yuhui Zhai, a graduate student at the University of Illinois Urbana-Champaign, invited attendees to play a video game simulation developed for the project.

Other topics ranged from designing smart work zone systems to analyzing transit ridership, advancing Illinois’ air mobility, predicting bridge deterioration, improving pavement design and more.

Together, IDOT and ICT have completed more than 320 projects, with more than 40 anticipated to be underway heading into 2025. Through this collaboration, they aim to steer the development and implementation of cost-effective technologies that enhance safety, reduce congestion and minimize environmental impacts.





## ▶ **NEWCOMB, SEIDERS AWARDED SECRETARY'S PIN FOR LIFESAVING EFFORTS**

Two employees were awarded the Secretary's Pin in recognition of lifesaving action. A Chicago minuteman rescued two women from a car engulfed in flames, while a District 6 snowbird's vigilance saved a crew filling potholes on Interstate 55 from a rogue semi.

### **NEWCOMB SAVES TWO FROM BURNING VEHICLE**

Throughout his 22 years with the department, Minuteman Steve Newcomb has come across many people in need of assistance, but on March 1, he encountered a situation he will never forget.

While patrolling the Kennedy Expressway (I-90/94), Newcomb noticed a few cars pulled over on the side of the road. He turned around to investigate and found a vehicle engulfed in flames with two young women inside.

"I immediately went up to the driver, who was screaming for help. By the time I got her out of the vehicle, everybody that had been standing there was gone," Newcomb said. "I put her down and went back to the vehicle to get the passenger, who was unresponsive and couldn't come out the driver side. I went around to the passenger side and pounded on the window. I was just about to break the window when the woman picked her head up, unlocked the door and passed out. I opened the door and moved her next to the other woman."

Once Newcomb had the women away from the burning vehicle, Illinois State Police arrived and began attending to the women. With them taken care of, Newcomb refocused his attention on the vehicle, pushing it out of the way until the fire department arrived to put out the fire.

On March 20, Newcomb received the Secretary's Pin for his heroic efforts.

### **SEIDERS SAVES COWORKERS FROM POTENTIALLY DEADLY CRASH**

Three-year Snowbird Don Seiders has a gift for being in the right place at the right time. On Feb. 1, Seiders was manning the attenuator truck with a pothole crew just south of Springfield on I-55 and diligently monitoring traffic when he saw a semitrailer barreling towards them.

Seiders quickly gauged the danger of the impending situation and acted fast, laying on his truck's air horn to warn the men filling potholes so they could run for safety. While the semi made a last-minute effort to turn into the other lane, it was too late. Seconds later, it smashed into the attenuator, destroying it and continuing forward, sideswiping the driver's side of Seiders' truck and stopping right where the men had been working. If not for Seiders' quick warning, a real tragedy would have occurred.

This is not the first time that Seiders has been in the right place at the right time. Almost one year to the day, Seiders and his crew were patching potholes on I-55 when a vehicle crashed into a bridge abutment. The crew rushed to help. When they arrived, the vehicle was on fire and people were trapped in the car. Seiders helped rescue two people, including a little boy.

On March 21, Seiders received his second Secretary's Pin for outstanding service to the department.





## ► **CORS** NETWORK TAKES SHAPE

A network of fixed monuments referred to as Continuously Operating Reference Stations designed to improve the accuracy of location data used for surveying, mapping, construction and engineering took shape this year.

In August, IDOT kicked off the project to establish the first free public CORS network in Illinois with Day Labor constructing sites in Litchfield, Petersburg and Jacksonville. The stations will serve as reliable reference points to continuously record and transmit 3D location data to satellites and other Global Navigation Satellite System receivers, enabling them to determine their position with greater precision. As part of a larger network, multiple stations share data to improve accuracy and coverage of a geographic area.

The permanent structures, known as driven-braced monuments, are deeply anchored tripodal fixtures made of stainless steel rods drilled 12 feet into the ground at precise angles. Antennae located within the structures are protected by a dome to prevent damage from the elements.

When complete, there will be approximately 70 sites statewide, forming a dense, public spatial network to which those with GNSS receivers can connect. These new sites will join roughly 2,000 others across the

United States that make up the fabric of the national CORS network.

In addition to surveying, there are myriad other uses for the technology, ranging from automated planting and harvesting to Illinois State Police crash reconstructions. The CORS network also measures tectonic plate movement, providing data to the National Oceanic and Atmospheric Administration's National Geodetic Survey.

The project is made possible by a portion of a \$4.5 million federal Advanced Digital Construction Management Systems grant awarded to IDOT in 2023. With matching state funds, the project totals \$6.25 million, with CORS being only one facet.





## ▶ WEST COLLEGE AVENUE RIVIAN MOTORWAY TO THE NSRR PROJECT

Construction started this year on West College Avenue and Rivian Motorway to the Norfolk Southern Railroad in Normal, with expected completion in 2026. The \$15.8 million project includes new traffic signals, a multiuse path, new sidewalks and other items. The project was funded by the Federal Surface Transportation Urban, State Truck Access

Route Program, the state Economic Development Program, congressionally directed spending, state COVID relief funds and Rebuild Illinois. In addition to serving the public, the improvements will serve Rivian Automotive's expanding vehicle manufacturing facilities and workforce.

## ▶ ENGAGING GENERAL ASSEMBLY AND STAFF AT BOWMAN PUMP STATION IN EAST ST. LOUIS

In August, members of the General Assembly and staff visited IDOT's Bowman Pump Station in East St. Louis. The group toured the facility and discussed ongoing operations and projects with district office employees at the site.

"IDOT appreciates the continued interest and support and values the opportunity to demonstrate our operations and groundwater management efforts that ensure the safety of our highways and communities," said Region 5 Engineer Kirk Brown.

Built in 1957, the Bowman Pump Station is strategically located near deep water wells and has a direct connection to the Mississippi River. If the river levels rise, more groundwater will be pumped to and from Alton and Columbia. In emergencies, the pump station is equipped with a 2,100-horsepower generator to ensure continuous power supply.

IDOT monitors groundwater at five locations and operates 35 pump stations across eight counties in the Metro East,

pumping groundwater, stormwater and sewage, including sewage stations located in rest areas and IDOT's facilities.





## ▶ IDOT TEAMS UP WITH ISU FOR MARKETING CAMPAIGN

IDOT is looking for new ways to reduce fatalities on Illinois roads, and this effort has taken them back to the classroom. The Office of Communications and the Bureau of Safety Programs and Engineering have partnered with marketing students from Illinois State University to create campaigns aimed at decreasing road fatalities caused by impaired driving, seatbelt non-use, distracted driving and more. This collaboration not only emphasizes the importance of traffic safety but also provides valuable industry-related experiences for the students.

The partnership began last fall, coordinated by DCC

Marketing, the Decatur firm that developed IDOT's ongoing "It's Not a Game" campaign. The project was designed to replicate the work that marketing students will encounter after graduation and to drive the importance of traffic safety while fostering industry-related experiences. Over the course of two sessions, students were briefed on the issues surrounding traffic safety in Illinois and IDOT's behavioral messaging efforts. They then spent several weeks preparing proposals for a final presentation, showcasing the benefits of innovative ideas from students and highlighting the importance of real-world experience in their proposals.





## ▶ A NEW PATH RISES ABOVE DIXON

New life has come to the old Illinois Central Railroad line that once ran through the heart of Dixon. The last train rolled through in 1985, but the first footsteps, bicycles and other non-motorized traffic are using it today thanks to a \$4.3 million project coordinated by IDOT and the city of Dixon.

Starting near IDOT's District 2 headquarters on Depot Avenue and ending at Dixon's downtown at Peoria Avenue and the Rock River, the path crosses high above city streets via three stone arch bridges crafted

from Galena limestone quarried locally in Dixon. Approaching downtown, the trail leaves the alignment via a graded wooden boardwalk designed to endure Illinois winters. Lighting and emergency call boxes line the path to add safety for users.

Plans are underway to extend the trail from the boardwalk spur across the Rock River into Page Park. There, the trail will have the capability to connect with trails that will travel outside of Dixon.

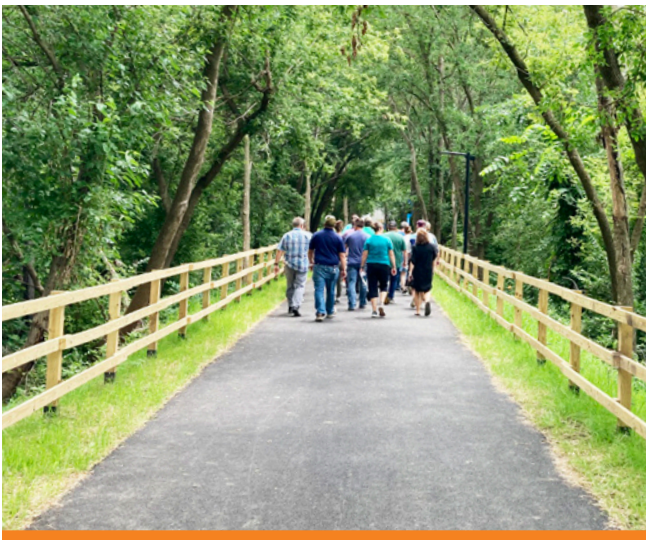



## ▶ MATTOON RECEIVES \$2 MILLION FOR ROAD IMPROVEMENTS FOR NEW SPORTS COMPLEX

Helping to promote strong economies, IDOT awarded the city of Mattoon with \$2 million in economic development program funds for upgrading and developing roads that will lead to their new \$80 million sports complex facility.

The Emerald Acres Sports Connection, which is scheduled to be completed in 2025, is a new 150-acre indoor/outdoor sports complex that features 22 baseball/softball diamonds, 20 soccer fields, two football fields, eight basketball courts and 16 volleyball courts.

Roads that were constructed or upgraded include Swords Drive, Remington Road, Fort Worth Way, and Wooddell Lane. IDOT helped provide direct oversight for the improvement of the roads.

Not only is Mattoon experiencing the growth from the sports complex, which is projected to generate more than \$23 million in direct spending and 59,000 booked hotel rooms annually, it is also experiencing a boom in business growth. Businesses including Chipotle, Chick-fil-A, Panda Express, Famous Footwear, Michaels, Five Below, Bealls Home Decor, Sierra, Ross and Ulta Beauty are just some of the locations visitors will find when visiting Emerald Acres.

IDOT is proud to have helped facilitate the future success of this great development for east central Illinois and the city of Mattoon. IDOT's Economic Development Program offers funding to local agencies to assist with road improvements to improve accessibility for new or expanding businesses.





## ▶ **ECONOMIC** DEVELOPMENT PROGRAM GRANT HELPS BUILD ROAD TO NEW PERU BUSINESS

In June, IDOT and leaders from the city of Peru celebrated the opening of Master Builders Way, a new road benefitting from a \$1.5 million grant provided by IDOT's Economic Development Program. The program provides state assistance for road improvements or new construction necessary for access to new or expanding industrial, manufacturing or distribution companies.

The focus of the program is to create and retain

permanent full-time jobs. For Peru, the construction of Master Builders Way provides access to a new GAF roofing manufacturing plant that's opening in an industrial park near Interstate 80.

The project not only supports jobs created by GAF but provides a catalyst for future business as the road runs a half mile through vacant lots ripe for development.

## ▶ **DISTRICT** 9 TOURS SHAWNEETOWN REGIONAL PORT DISTRICT

On Sept. 24, District 9 and Central Office employees joined members of the General Assembly and their staff, Old Town Mayor Bill Barton and Shawneetown Mayor Steve Wood for a tour of the Shawneetown Regional Port project. The group took a deep dive into Shawneetown's history, including its economic development and the plan for road and port projects taking place at the site.

The Shawneetown Regional Port District has secured more than \$27 million in private and public funding for the port project, including more than \$10 million in federal funds from the U.S. Maritime Administration and competitive grants from IDOT. The efforts aim to enhance the safety and reliability of intermodal connections in southeastern Illinois.





# DIVERSITY, EQUITY AND INCLUSION

**Our workforce and industry must** reflect the people we serve and echo their voices. The end product of our work is always made better through the lens of diversity, equity and inclusion.





**IDOT**

MILLISTRE

27

4'

4'





## ▶ **TODAY'S** CHALLENGE, TOMORROW'S REWARD: IDOT CONFERENCE RETURNS

IDOT hosted the 33rd Today's Challenge, Tomorrow's Reward conference on Feb. 21 and 22 at the Crowne Plaza in Springfield. Organized by IDOT's Office of Business and Workforce Diversity, the conference provides female- and minority-owned businesses with opportunities to make connections and develop skills to grow and succeed.

"Today's Challenge, Tomorrow's Reward can open doors that lead to new, exciting paths to grow your business and positively impact your community while helping IDOT make projects more diverse and inclusive," said Illinois Transportation Secretary Omer Osman. "Under Gov. Pritzker and the historic Rebuild Illinois capital program, Illinois is seeing record levels of investment in transportation. Please join us in shaping and modernizing infrastructure for future generations."



TCTR offers workshops to build skills, seminars on best practices and networking opportunities for firms and contractors wanting to do business with the state through the Disadvantaged Business Enterprise program.

Conference topics included work category expansion, funding, training opportunities, "getting paid" and construction safety. Industry leaders and IDOT staff also lead sessions on how to bid on, participate in and deliver projects. Speakers included Bradley Mims, Director of the U.S. Department of Transportation Office of Small and Disadvantaged Business Utilization, and Aaron Davis, a football national champion at the University of Nebraska, author, businessman and cancer survivor.





## ➤ **NEW** DBE RESOURCE CENTER FOR I-80

As part of Gov. Pritzker’s directive to include small, local businesses on the I-80 reconstruction project, IDOT has opened a new DBE Resource Center at 858 Center Court, Unit A, in Shorewood.

Furnished with a computer lab and office equipment,

the resource center will act as a free one-stop shop offering one-on-one assistance for firms that want to become certified DBEs and learn about contracting opportunities in the area without having to travel to meet with IDOT staff in Chicago or Schaumburg.

## ➤ **A** NEW ATTENDANCE RECORD FOR THE TCTR CONFERENCE



**IDOT**



# 401

## 2024 CONFERENCE ATTENDEES





## ➤ RECRUITERS WORK HARD TO MAKE IDOT WORKFORCE DIVERSE

The Diversity and Recruitment Section in the Bureau of Personnel Management is hard at work to bring talent and focus on attracting talented individuals to IDOT. Staffed by Recruitment Section Manager Aisha Price, Northern Recruitment Manager Ivan Barajas and Recruitment Managers Tiffany McCabe, Clayton Yantis, Jennifer Boster and Deborah Williams, the team employs innovative strategies to build a diverse workforce and enhance outreach to underrepresented groups.

Key efforts include hosting successful career fairs, engaging with historically Black colleges and engineering programs, and utilizing platforms like Handshake and Indeed for job postings. In alignment with Secretary Osman's vision, IDOT aims to inspire younger students to pursue careers in transportation. These initiatives demonstrate IDOT's commitment to effectively meeting recruitment needs.





## ▶ ROCK VALLEY COLLEGE HCCTP GETS UP CLOSE TO ROCKFORD'S I-39/ U.S. 20 INTERCHANGE

Students enrolled in Rock Valley College's Highway Construction Careers Training Program have been on field trips to materials labs and discussed construction with local contractors. In May and November, the students did something different: They visited the IDOT construction site of the new Interstate 39 and U.S. 20 interchange in Rockford.

"To blend classroom discussion and lessons about infrastructure, bridge repair, green technology, etc., with boots on the ground seeing it all in action was too good to be true," said Dawson Ingram, Rock Valley's HCCTP coordinator.

The visits were coordinated by RM Chin, one of the I-39 project consultants, and IDOT's District 2. During both visits, students went to the I-39 construction office for

a briefing about the project before visiting the worksite. Each group got a chance to view various aspects of the construction, with the May group of students seeing the excavation of the new southbound I-39 ramp and the November group seeing the project as it neared completion.

HCCTP is an IDOT-funded program that aims to help women, underrepresented and socioeconomically disadvantaged individuals gain acceptance into the construction trades. During the 14-week class, participants will engage in 450 hours of skilled-trades preparation and apprenticeship readiness training with the goal of applying for and obtaining local union apprenticeship opportunities.

▶ NUMBER OF HCCTP GRADUATES IN 2024

233



IDOT





# ACCOMPLISHMENTS

**Whether it's the individuals,** teams or projects that garner praise, we are humbled when our work is recognized and feel a great sense of honor to have been given the opportunity to excel.



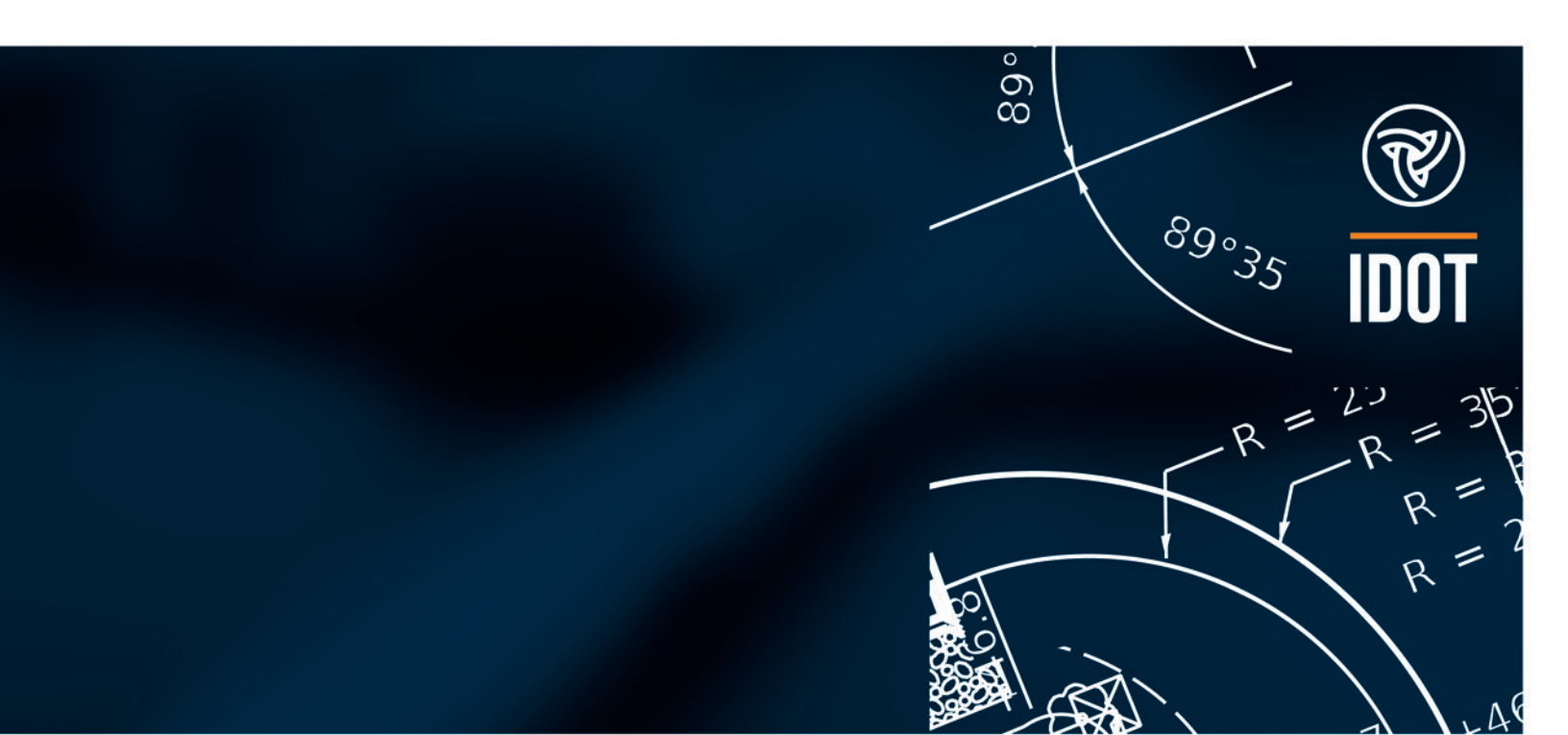

**IDOT**





## ▶ THE OFFICE OF COMMUNICATIONS BRINGS HOME FIVE TRANSCOMM AWARDS

The Office of Communications won a record number of awards at the American Association of Highway and Transportation Officials' Committee on Transportation Communications (TransComm) Annual Meeting on Sept. 24. The awards in the yearly skills competition are given for excellence in transportation communication, recognizing the best of the best nationwide.

Departments of transportation are allowed to submit in six categories. The IDOT team, with five wins – the most won by a single state in this year's competition – took home the top prize in all but one of the categories entered. Winning submissions included:

- ❑ **Top Communications Campaign of the Year with a Consultant** for "It's Not a Game" with the Bureau of Safety Programs and Engineering and DCC Marketing of Decatur.

- ❑ **Publication of the Year** for the FY 2025-2030 Proposed Highway & Multimodal Improvement Program publication with the Office of Planning and Programming and related efforts with fact sheets, social media graphics and branding under Rebuild Illinois.
- ❑ **Photo of the Year** for the Hillsboro sinkhole with District 6.
- ❑ **Best Creative Use of Social Media** for the Coney campaign featuring Claims Specialist Zipporah Williams in a construction cone costume in nontraditional places promoting safety.
- ❑ **Best External Publication** for "The Telegram" and strategies to get articles picked up and published by external outlets over traditional press releases.





## ▶ ILLINOIS HIGH-SPEED RAIL PROJECT A FINALIST FOR AASHTO AWARD

The Illinois Department of Transportation's Chicago-to-St. Louis rail improvement project, "Connecting Illinois via High-Speed Rail," was a Top 12 finalist for project of the year in the annual America's Transportation Awards, hosted by the American Association of State Highway and Transportation Officials, AAA and the U.S. Chamber of Commerce.

The "Connecting Illinois via High-Speed Rail" project upgraded the Chicago-to-St. Louis corridor, allowing train speeds to rise from 79 mph to 110 mph. The \$2 billion initiative improved service along the Midwest's

most heavily traveled passenger rail route while encouraging a more balanced use of transportation modes.

The project also benefited communities including Joliet, Dwight, Pontiac, Normal, Lincoln, Springfield, Carlinville and Alton. All of these communities have new or renovated stations with improved amenities, such as free Wi-Fi and expanded bicycle accommodations. Additionally, improvements like four-quadrant gates, pedestrian gates, loop detectors and fencing have increased safety.

## ▶ SECRETARY OSMAN HONORED AS A CHAMPION OF AVIATION



Illinois Transportation Secretary Omer Osman was honored with the Champion of Aviation Award, presented by the Illinois Public Airports Association earlier this year in Galena. Sandra Shore, the newly elected chairman of the association and director

of the St. Louis Downtown Airport, presented it to Secretary Osman.

Through Gov. Pritzker's Rebuild Illinois capital program, IDOT is investing \$150 million in aviation. In 2021, the governor announced with IDOT a \$94 million commitment to airports throughout the state, unlocking \$11.5 million in local contributions for a combined investment of \$105.5 million. The funding was the largest statewide capital investment for airports in state history.





## ▶ **BOB** MICHEL BRIDGE TAKES HOME TWO APWA AWARDS

Peoria's Bob Michel Bridge rehabilitation brought home two awards from the American Public Works Association Illinois Chapter for 2023: Project of the Year and an award for transportation projects less than \$25 million. The project included a new deck, a first since the bridge opened in 1993.

The \$24.6 million project also included structural repairs, modernized traffic signals and drainage improvements. Narrow sidewalks on both sides of traffic were consolidated into a 14-foot-wide path protected from Illinois 40 by a concrete barrier,

providing a safer travel option for people who walk, bike and roll, while providing connections to the region's trail network, including the Rock Island Greenway Trail and the River Trail of Illinois. New LED lighting was installed to improve visibility and safety.

By closing the bridge completely to cars and trucks and not performing the work in multiple phases, the project was completed in less than a year, resulting in time and cost savings. The safety risk to workers and the public also was reduced by eliminating traffic moving through the work zone.



## ➤ KIRK WINS DAVE CAMPBELL QUALITY AWARD

Chief Internal Auditor Stephen Kirk was honored with the Dave Campbell Quality Award at the American Association of State Highway and Transportation Officials' Internal and External Audit Conference Aug. 20 for outstanding service in auditing for a state department of transportation.

Kirk has served as IDOT's voting member on the AASHTO Internal and External Audit Committee since 2011 and as co-chair of the Internal Audit Practices Subcommittee for 10 years. During this time, he helped develop conference breakout sessions, introduced internal audit roundtables to provide a forum for internal auditors to share best practices and developed practice aids to provide specific guidance on internal audits. He also assisted with revamping the "Internal Audit Practices Guide."

Kirk has served as a member of the AASHTO Internal and External Audit Committee Board since 2019, with two-year terms each as chair, vice chair and secretary. During his tenure he introduced the information technology audit working group and internal audit practices virtual round tables, coordinated with the American Council of Engineering Companies and worked with states to update the "External Audit Practices Guide." He also added "Intermodal Day" to the conference, addressing auditing of all modes of transportation.

The Dave Campbell Quality Award is presented by the AASHTO Committee on Internal and External Audit in recognition of significant contributions to the state DOT audit community. The award is named after a former IDOT Chief of Auditing who helped establish the AASHTO Internal and External Audit Committee.



## ➤ HIGHWAY MILES UNDER STATE JURISDICTION



IDOT

15,899



# STAY CONNECTED



[idot.illinois.gov](http://idot.illinois.gov)



[twitter.com/idot\\_illinois](https://twitter.com/idot_illinois)



[facebook.com/illinoisdepartmentoftransportation](https://facebook.com/illinoisdepartmentoftransportation)



[linkedin.com/company/illinois-department-of-transportation](https://linkedin.com/company/illinois-department-of-transportation)



[instagram.com/idotimages](https://instagram.com/idotimages)



[threads.net/@idotimages](https://threads.net/@idotimages)



[flickr.com/photos/idot\\_illinois](https://flickr.com/photos/idot_illinois)



[youtube.com/user/IllinoisDOT](https://youtube.com/user/IllinoisDOT)



# SOCIAL MEDIA STATS



**1,680,000:** UNIQUE VISITORS TO IDOT.ILLINOIS.GOV IN 2024



**169,000:** FACEBOOK FOLLOWERS



**64,900:** X FOLLOWERS



**10,100:** FLICKR PHOTOS



**8,400:** INSTAGRAM FOLLOWERS

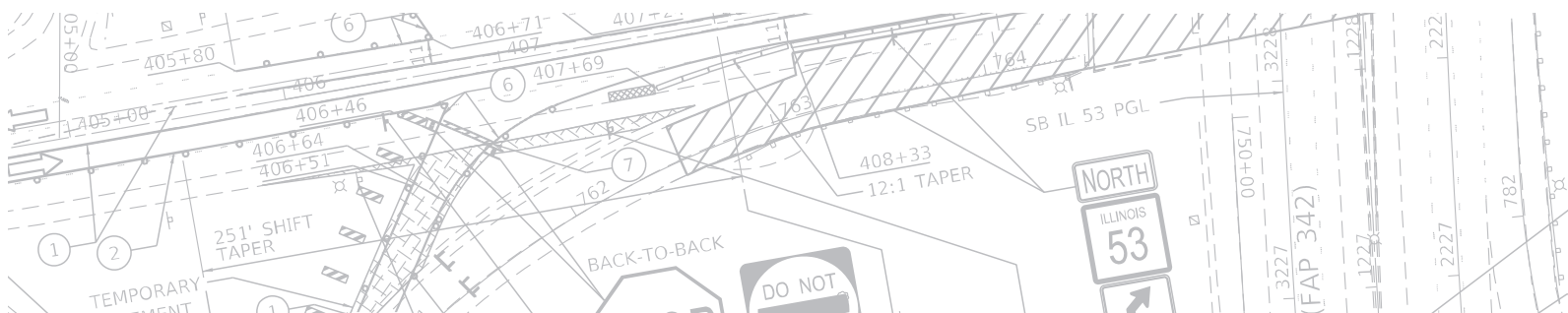



IDOT

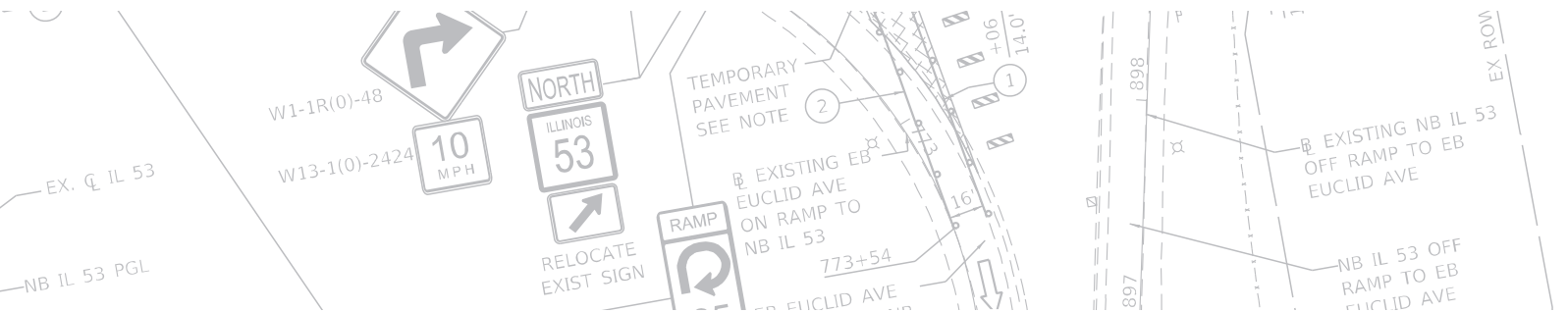

# 2024 ANNUAL REPORT

